

1. Choose a level location for your Triumph Display Easel.

2. The Triumph Display Easel is adjustable from 37" to 62" high.

To adjust the height of the easel, simply:

2.1 Spread the three legs by snapping each leg away from the support braces.

2.2 Locate the snap button and gently depress while sliding the lower easel leg until the snap button engages in the fully extended position. Repeat for all three legs. Please note that it is possible to pull the lower leg off. If this happens, simply depress the snap button and slide the leg back on.

3.0 To use your Triumph Display Easel at the 37" height, it may be necessary to move the two board holder as follows:

3.1 Depress the snap button and remove the lower leg.

3.2 Move the board holder to the desired location and hold in place while depressing the snap button and replacing the lower leg.

4.0 Swing the two board holders into position. Gently rest your presentation on the board holders.

Please note that your Triumph Display Easel can hold a maximum of 25 pounds and is intended for display purposes only.

TRIUMPH DISPLAY EASEL

INSTRUCTION SHEET

GHENT
MANUFACTURING, INC

IS19250

REV	DATE	DESCRIPTION	BY

PRINTING INSTRUCTIONS:

- PAPER STOCK — 60 LB OFFSET
- CUT SIZE — 8 1/2" X 11"
- COLOR INK — MEDIUM BLUE
- PRINT SIDES — ONE SIDE

- FOLDS — NONE
- DRILLED — NONE
- PACKAGING — SHRINK WRAP IN 500 SHEET BLOCKS

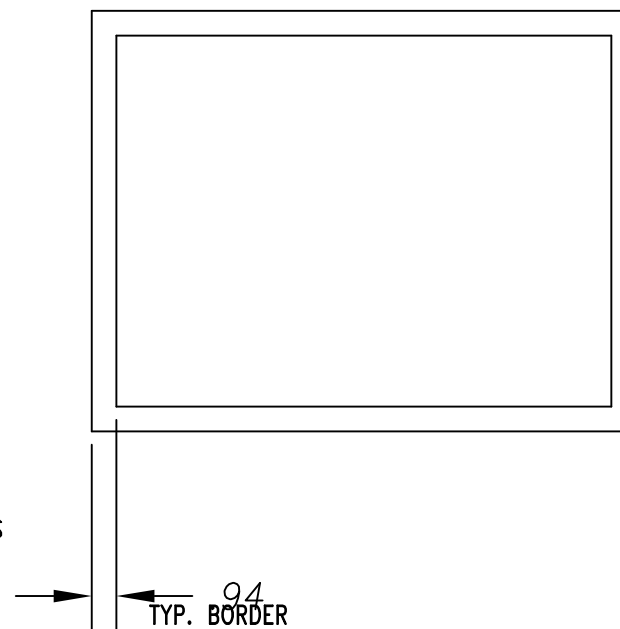

DISKETTE COPY (AutoCAD R12) IS AVAILABLE FROM
 GHENT MANUFACTURING, INC. FOR TRANSFER TO FILM.
 PLEASE REFER TO PART NUMBER WHEN REQUESTING DISK.

THIS DRAWING IS PROPERTY OF GHENT MANUFACTURING, INC. ANY DUPLICATION OR DISTRIBUTION IS PROHIBITED WITHOUT WRITTEN CONSENT FROM GHENT MANUFACTURING.	TOLERANCES (EXCEPT AS NOTED)			GHENT MANUFACTURING INC
	DEC. ±	FRAC. ±	ANG. ±	
WHERE USED: 19250	DRAWN BY: MAB			INSTRUCTION SHEET SPECIFICATION
QTY. PER ASSM.: 1	DATE: 1/24/00			
MATERIAL: NOTED	APP'D:			DRAWING NUMBER:
FINISH: -----	SCALE: NONE			PART NUMBER: IS19250
				SHEET 2 OF 2

Series 19250

TRIUMPH DISPLAY EASEL

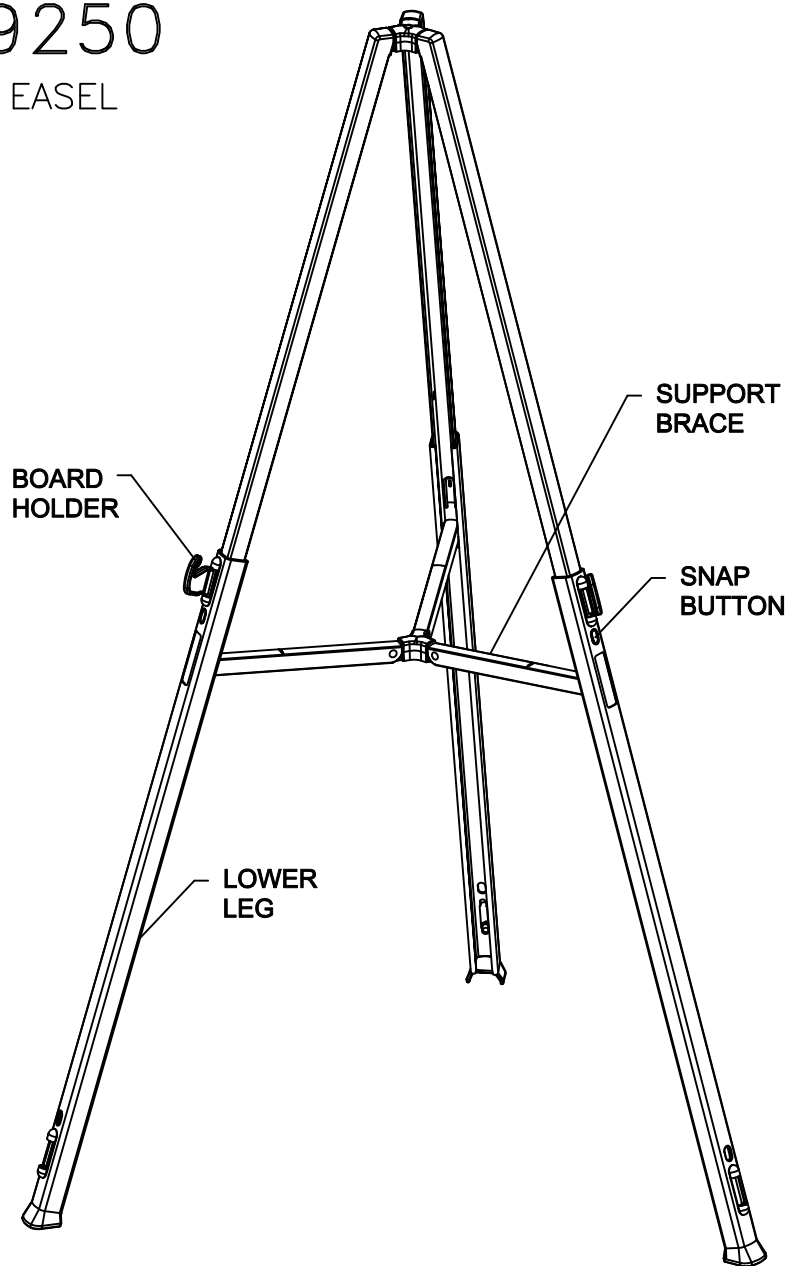

Specifications

The 19250 patented design delivers strength and stability. The plastic legs of the easel retract for easy storage & handling. All three legs have rubber stoppers to keep slippage to a minimum. The inverted leg design adds strength and stability, and extends from 37" up to 62". The Triumph easel has permanently positioned board holders. It carries a 1-year guarantee. When fully extended, the legs have a 3 foot span in all directions. Recommended maximum load is 25lbs. Ships via Fed Ex or UPS.